

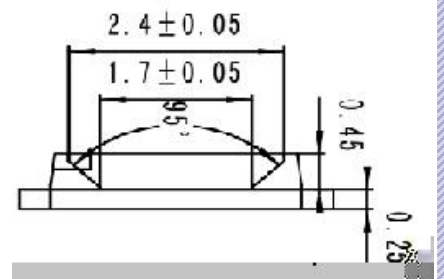

SHENZHEN LIGHT ELECTRONICS CO., LTD

: _____
 :
 : _____
 :
 : SL-T2835P01-V1A5
 : _____
 : _____
 : _____
 : _____

Client approval			approval		
Approved	Checked	Audit	Approved	Checked	Prepared
Qualified		Disqualified			

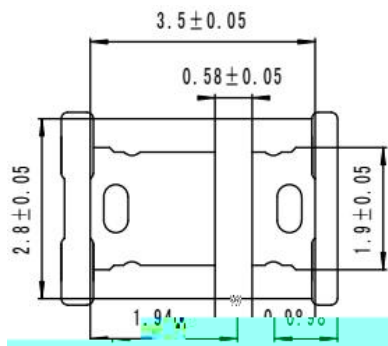
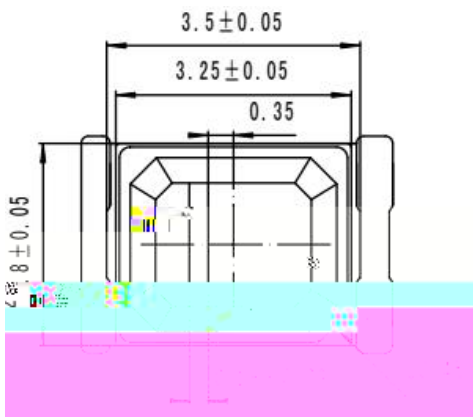
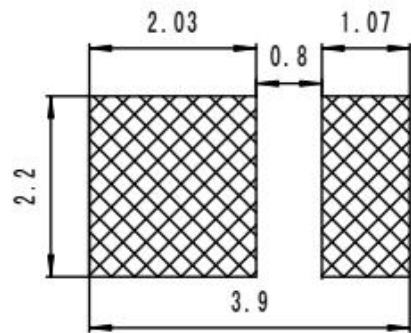

()

()



SHENZHEN LIGHT ELECTRONICS CO., LTD

2835							

()

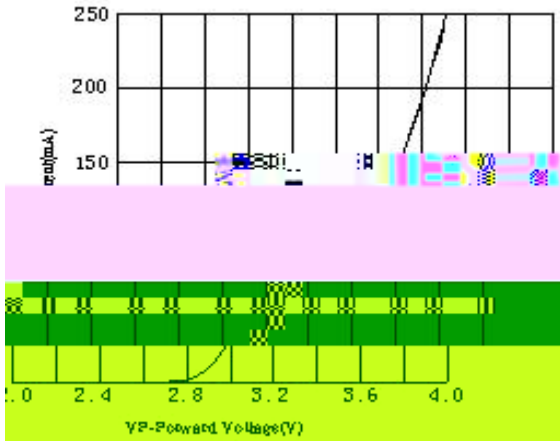

Fig.1 Forward Current vs Forward Voltage

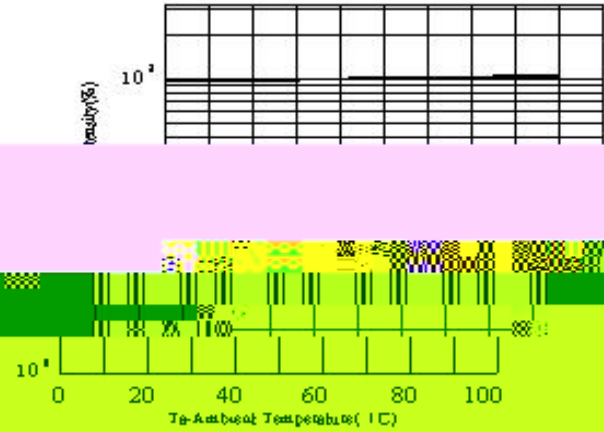
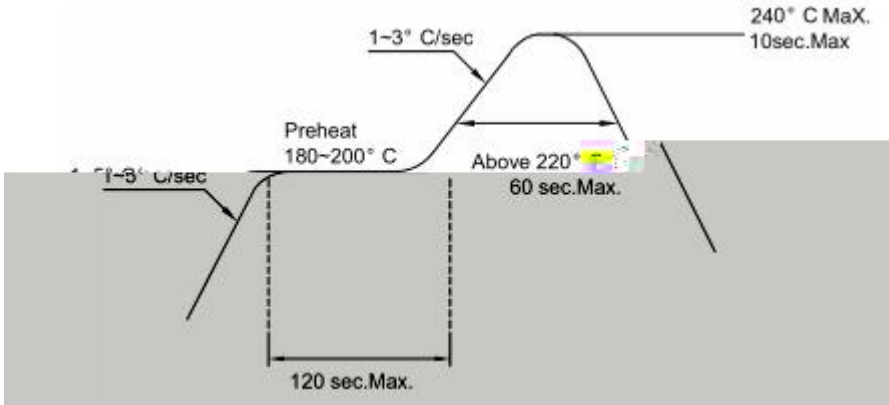

Fig.2 Relative luminous Intensity vs Ambient Temperature



&Repairing

10s

220

240



70 /6-8H

LED 150 /3H

±

3

70 &6-8

.ž

ДЪН

Lb

BCNPO

LED

Lb
E352

p

100PPM

F2

Гр.р - €0,09 и в λ0,0001 - €р λ0,0001

LIGHT[®]

